

## Pandora would like to thank you for choosing our DXL-0100L/0101L service and security system

**Pandora** is a brand of Russian Experimental Engineering Factory, a full production cycle electronics R&D facility. We design and produce car service-security systems for more than 10 years and have reached a considerable success on Russian and post-communist markets – biggest security system markets in the world. Our systems are made to withstand severe weather conditions and criminal situation of northern Eurasia.

**Pandora DXL-0100L/0101L** is a car service-security system, built for cars with on-board voltage of 12V. It is a complex engineering solution which includes car security system, algorithmic security that detects various events and immobilizer with possible RF tags, all controlled from your OEM key remote. This system is designed to be all-in-one car security solution and requires no additional modules. Note that 'no tags' version can be complemented with RF immobilizer tags sold separately, or immobilizer can be controlled with a PIN dialed using original car buttons.



### WARNING!

IT IS STRONGLY ADVISED TO HAVE PROFESSIONAL CAR MECHANIC INSTALLING THE SYSTEM. CERTIFIED INSTALLERS ARE RARE OUTSIDE RUSSIA, BUT ANY CAR ELECTRONICS INSTALLER SHOULD BE ABLE TO INSTALL PANDORA DXL-0050L USING INSTALLATION SCHEME IN THIS MANUAL AND ALARMSTUDIO SOFTWARE. MOST FEATURES ARE HIGHLY DEPENDENT ON COMPETENT INSTALLATION. OUR SYSTEMS ARE THOROUGHLY TESTED FOR QUALITY, SO IF A FEATURE FAILS TO PRODUCE EXPECTED RESULTS, MOST LIKELY THE PROBLEM IS IN IMPROPER INSTALLATION.

It is essential for systems functioning that you read and understand instructions in this manual. Note that all radio devices are subject to interference, which could affect proper performance.

This device has limited external factors resistance. It should not be subjected to water beyond occasional splatter, or operated in temperatures outside -40 to +80 °C range.

**IMPORTANT! Note that this manual describes remote and manual functions for the most part. Functionality of the system is vast and would require a book-sized manual to fully describe. Instead we use a handy software named AlarmStudio that functions as both programming tool and an extended installation & functionality manual. It requires Windows and can be downloaded at [pandorainfo.com](http://pandorainfo.com)**

## Table of contents

<b>General information</b>	<b>4</b>
System features	4
System set	5
<b>Control over system</b>	<b>6</b>
Arming/disarming using radio tag button	6
Arming/disarming in Hands Free mode	6
Arming/disarming in slave mode	6
Immobilizer mode	7
Antihijack mode	7
Replacing immobilizer tag battery	8
Immobilizer code using original car controls	8
Control over system in case of emergency	8
<b>Installation and configuration of the system</b>	<b>10</b>
General installation requirements	10
Wiring description	11
Programming system and entering PIN-code	12
Changing core settings via computer	13
Configuring system settings via the wireless interface 2,4 GHz	14
Entering the programming menu using VALET button	14
Changing core settings via VALET button	15
Wiring diagram	16

<b>Additional devices</b>	<b>20</b>
Blocking radio relay	20
RR-100 Radio relay connection	20
Programming of radio relay	21
Radio module of engine compartment RHM-02	21
Programming mode (recording) of RHM-02 module	23

<b>Important information</b>	<b>24</b>
Any problem can be solved	24
Siren sounds and turn light signals	25
Meaning of the indicator LED colors	25
Glossary of terms	26
System modules layout	27
Warranty obligations	30
Installation certificate	31
Acceptance certificate	32
Warranty card	32

## GENERAL INFORMATION

### System features

#### Base unit

- Dialog coding of control commands.
- Individual 128-bit encryption key.
- Individual disarming PIN-code.
- RC blocking relay (2,4 GHz, frequency, up to 3 units can be connected).
- Built-in integral accelerometer for determining motion and shocks with adaptive processing algorithm and sensitivity controls via the remote.
- Built-in 2,4 GHz aerial.
- Advanced process of sensor data reading, eliminating false alarm possibilities.
- Automatic arming.
- Registers delay for interior lighting when arming.
- Hands Free mode for arming/disarming without using a remote.
- Software updates via built-in micro-USB socket.

#### Immobilizer tags

- Dialog coding of control commands.
- Individual 128-bit encryption key.
- Built-in LED indicator.
- Built-in button to control over security modes.
- CR-2032 battery.

#### Car security zones

Pandora DXL-0100L/0101L service-security system guards following independent zones with corresponding zone notifications on the remote and recording alarms into the event history:

- car doors perimeter (separate for every door)
- front hood triggers
- trunk triggers
- ignition trigger

- brake pedal button
- triggering of the shock sensor (warning level)
- triggering of the shock sensor (alarm level)
- triggering of the motion sensor
- triggering of the tilt sensor
- critically low on-board voltage
- marker lights left on notification when arming\*

### System set

1. Base unit	1
2. Immobilizer tags (only for DXL-0100L)	2
3. Leather case for tags (only for DXL-0100L)	1
4. Main cable	1
5. Cable with VALET button and three-colored light indicator	1
6. Fastening kit	1
7. Siren	1
8. User installation manual	1
9. Plastic card with individual secret code	1
10. Packaging	1
11. Beeper (compact sound emitter)	1

**Manufacturer reserves the right to change set and construction of the product to improve its technological and operational parameters without notification.**

---

\* Availability of this function depends on car make and model

## CONTROL OVER SYSTEM

### Arming/disarming using radio tag button

To arm/disarm the system, RF tag should be in radio coverage area (within a radius of 5 meters from the car). The system produces a protected (AES-128 encryption) interactive high-speed exchange of authorization codes in the frequency range 2,4 GHz on one of 125 channels. To arm the system when the ignition is switched off, shortly press the tag button. The system will confirm the command receiving with 1 short sound signal and 1 flash of turn indicators. To disarm the system, shortly press the tag button. The system will confirm the command receiving with 2 short sound signals and 2 flashes of turn indicators. Each button press will be confirmed with LED indicator flash of the tag that indicates the battery is functioning correctly. If LED indicator does not flash or light, the tag battery should be replaced (see 'Replacing immobilizer tag battery' section).

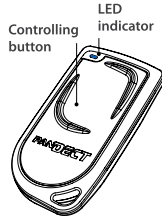

### Arming/disarming in Hands Free mode

The system allows for programmable **Hands Free** arming and disarming. To arm the system when the engine is not running, move with the remote tag away from the car at a distance greater than the regular radio coverage (10 meters for 2,4 GHz) – the system will be armed automatically. To disarm the system, move toward the car with remote tag.

### Arming/disarming in slave mode

In this mode it is possible to monitor the status of original security system of the car via CAN-bus or by analog inputs. When arming and disarming original security system, Pandora will be armed and disarmed respectively. The presence of a tag in the radio zone is not required, but at the beginning of motion if the tag is not detected by the system, the engine will be blocked.

There is an option in the system settings named 'Disable disarming when the tag is not present'. When this option is enabled, disarming procedure will be performed only if there is a tag in the radio zone.

**Pandora DXL-0100L/0101L is innovative and highly effective security solution that helps prevent aggressive seizure of the car (hijacking) with the use of 2 immobilizer tags. To strengthen the defenses of the car, additional blocking relays can be installed (up to 3).**

### Immobilizer mode

This mode is enabled by default. When engine is running, base unit of Pandora security system performs a search for immobilizer tags in radio zone. If no tags were detected, LCD remote will play **'NO TAG FOUND'** ringtone. If no radio tags were detected when the ignition is switched on, the system will block the engine with all radio relays that were programmed into the system. Engine blocking will only occur when motion sensor detects movement of the car. If additional analogue blocking relays were installed, they will block the engine immediately, before or when the car starts moving, it depends on system settings.

### Antihijack mode

This mode is disabled by default. **Antihijack mode** helps to prevent aggressive seizure of the car using delayed engine blocking on door opening.

Every time when the engine is running on opening/closing a door, immobilizer requests response from a remote using unique algorithm. After a door was opened while the engine is running, if the system cannot detect a radio tag, the engine will be stopped after 1 minute (general safety requirement). **'ENGINE BLOCKING WARNING'** ringtone will play before blocking.

If engine blocking is performed via radio relay after warning signals are over or on new attempts to start the engine, immobilizer will only allow the engine to start when the car is not moving, and will block it again if it starts movement. If the car starts moving, the immobilizer will block the engine for 15 seconds. When registered tag appears in the radio zone, blocking will be canceled and the system will return to the normal operation.

If the engine is blocked via analog relay, engine operation will be stopped after warning signals are over, until a registered tag appears in the radio zone or on registering movement – depending on the settings.

## Replacing immobilizer tag battery

Carefully open the cover of the tag's battery compartment. Extract discharged battery and insert a new one keeping in mind the correct polarity. Replacing a battery will not cause a loss of tag code information, as authorization data is stored in the non-volatile memory of the MCU.

Carefully close the cover of the tag's battery compartment. All elements of construction should be rigidly locked in places. If it is so, the tag can be operated as usually.

## Immobilizer code using original car controls

Code immobilizer is a function that allows disarming and controlling timer channels using original car controls (button, lever or pedal). To enter immobilizer code, programmed button (lever, pedal) should be pressed a number of times equal the digit of the code. Pauses between presses should not exceed 1 second. Pauses more than 1 second will be interpreted as the start of next digit input. Immobilizer code can consist max of 4 digits from 1 to 9.

After entering a correct immobilizer code, depending on the settings, either the engine blocking will be lifted or a programmed timer channel will be activated.

## Control over system in case of emergency

### Emergency disarming/switching off immobilizer using VALET button

In case you cannot disarm the system using a remote, owner's individual PIN-code can be used. Individual PIN-code is written on the owner's plastic card under protective layer. Erase the protective layer and use VALET button to input PIN-code.

1. Using VALET button, input the first digit of the code (press the button a number of times, equal to the first digit; pauses between presses should not exceed 1 second). The system will confirm with red LED indicator flash.
2. Similarly input the second, third and fourth digit. Every input will be confirmed with red LED flash.
3. The system will confirm correct PIN-code with red and green flashes of LED indicator. If the input was incorrect, it will be indicated with long red flash. New input can be attempted after 5 seconds.

### If immobilizer/Antihijack mode is activated:

4. Using VALET button, input PIN-code. Factory preset PIN-code is **1-1-1-1** (4 presses with pauses for 2 seconds).
5. The system will confirm correct PIN-code with red and green flashes of LED indicator and will enter programming mode. New input can be attempted after 5 seconds.
6. To switch off immobilizer/Antihijack function, press VALET service button 15 times (pauses between presses should not exceed 1 second). The LED will be lit green.
7. Input individual PIN-code similar to emergency disarm. The system will confirm correct PIN-code with 2 short signals of the siren and with red flash of LED.
8. To activate immobilizer/Antihijack function, enter level 15, the system will confirm it with red flash of LED. Press VALET button once, the system will confirm it with green flash of LED and with 1 short signal of the siren.

For emergency arming when the engine is stopped, press and hold VALET button for 3 seconds. The system will be armed in 30 seconds.

While there is a countdown, the LED will be lit red.



**WARNING!**  
MAKE SURE THAT PROTECTIVE LAYER ON THE OWNER'S PLASTIC CARD IS INTACT AFTER THE INSTALLATION OF THE SYSTEM. PLASTIC CARD HOLDS INDIVIDUAL PIN-CODE.

## INSTALLATION AND CONFIGURATION OF THE SYSTEM

### General installation requirements

- Only install base unit inside car interior.
- Install securely each system's component, as conditions of the car standard operation can harm functionality of the alarm system and cause damage to the car original systems, including the elements of safety in motion.
- The system installation should be performed when the system sockets and the negative battery terminal are disconnected.
- The base unit power supply should be switched off when connecting to CAN-bus.
- The system installation can be performed via twisting together or via lead-tin soldering followed by isolation of a switching place.
- When wiring, pay attention to sections and materials of switched conductors, if they are different, bring electrochemical potentials to the minimal difference. The isolation should not allow for moisture to reach wiring, as the presence of moisture will increase electrochemical destruction of wires (this is especially important for the large current circuits).
- Switched connections should be placed as high as it is possible in the cavities so water condensate will not form drops on the switching location.
- To avoid the destruction of compounds by car vibration, ensure that there is a bit of free length to the wiring, providing enough sagging.
- Do not allow wiring in places where the wires isolation can be destroyed by abrasion.
- Electronic system units should be placed sockets down and as high as possible to avoid condensate reaching electronic components through the socket.
- When installing base unit, secure it to the car body for correct operation of in-built shock sensor.
- All unused system wires during the installation must be insulated and secured to prevent accidental touching of a car body or other wires.

### Wiring description

#### Base unit connection

**Wire 1** (White) (DATA TX) It connects to appropriate additional devices wires (optional).

**Wire 2** (Red-black) (LED/VALET) It should be connected to the red wire of LED/VALET button. Black wire connects to the grounding spot.

**Wire 3** (Orange-white) ('CAN1-High') It connects to appropriate CAN-High wire of the car.

**Wire 4** (Yellow-white) ('CAN2-High'/OUT-2) Factory setting is 'Open central lock'. A negative impulse of 0,8 seconds is formed on the wire to open central lock. Logic of the channel's operation can be set in the table of system outputs in AlarmStudio. When the channel is cleared from assigned operating algorithms, it starts operating as CAN2-High and the wire connects to appropriate CAN-High car wire.

**Wire 5** (Grey) (INP-1/OUT-1) Factory setting is 'Door switches'. This wire connects to a wire that becomes grounded when the door opens. This input is multipurpose, it can operate in accordance with selected logic.

**Wire 6** (Green) (INP-4/OUT-4) Factory setting is 'Control turn indicators'. This wire connects to the hazard flashers button. This channel is multipurpose, it can operate in accordance with selected logic.

**Wire 7** (White-blue) (INP-5) Factory setting is 'Brake pedal limit switch'. This wire connects to the brake pedal button where 12V voltage appears when the pedal is pressed (stop lights wire). Brake pedal signal is one of the system's security zones. This input is multipurpose, it can operate in accordance with selected logic.

**Wire 8** (Black) (ground) It should be connected to the car body in a grounding spot. This wire should be connected FIRST during installation.

**Wire 9** (Blue) (DATA RX) It connects to appropriate additional devices wires (optional).

**Wire 10** (Brown-white) (INP-3) Factory setting is 'Front hood and trunk limit switch'. This wire connects to appropriate wire that becomes grounded when the front hood opens. This input is multipurpose, it can operate in accordance with selected logic.

**Wire 11** (Orange-black) ('CAN1-Low') It connects to appropriate CAN-Low wire of the car.

**Wire 12** (Yellow-black) ('CAN2-Low'/OUT-5) Factory setting is 'Close central lock'. A negative impulse of 0,8 seconds is formed on the wire to close central lock. Logic of the channel's operation can be set in the table of system outputs in AlarmStudio. When the channel is cleared from assigned operating algorithms, it starts operating as CAN2-Low and the wire connects to appropriate CAN-Low car wire.

**Wire 13** (Blue-black) (OUT-3) Factory setting is 'Blocking'. This wire is used to control external analogue blocking relay with a normally open logic (it becomes grounded when switching on the ignition and security system is not armed and radio tags are in range).

**Wire 14** (Yellow) (INP-2) Factory setting is 'Ignition'. This wire connects to ignition switch or to appropriate wire where 12V voltage appears when ignition is switched on and doesn't disappear until the moment ignition is switched off. This input is multipurpose, it can operate in accordance with selected logic.

**Wire 15** (Purple) ('siren') It connects to siren control wire (+) (maximum load current is 2A).

**Wire 16** (Red) ('Power supply' 12V) It should be connected to reliable conductor with constant voltage of 12V.

## Programming system and entering PIN-code

The system settings can be changed via computer. The system should be connected to a computer via standard micro-USB cable and a special piece of software – **Pandora AlarmStudio**.

**AlarmStudio can be downloaded from the official company web-site [pandorainfo.com](http://pandorainfo.com)**

### Entering programming menu:

1. Disarm the system, switch off the ignition.
2. Connect the base unit of the system to a computer via micro-USB cable.
3. Using VALET button, input service PIN-code. Factory preset PIN-code is **1-1-1-1**.
4. Using VALET button, input the first digit of the service code (press the button a number of times, equal to the first digit; pauses between presses should not exceed 1 second). The system will confirm

entering of the first digit with red LED indicator flash.



**WARNING!**  
IF YOU ARE AN INSTALLER, DO NOT ERASE PROTECTIVE LAYER OF THE OWNER'S PLASTIC CARD! IN CASE A CUSTOMER COMPLAINS ON ERASED PROTECTIVE LAYER OF THE CARD WITH THE INDIVIDUAL PIN-CODE, RE-INSTALLATION OF THE SYSTEM IS CARRIED OUT AT THE EXPENSE OF THE INSTALLER.

5. Similarly input the second, third and fourth digit. Every input will be confirmed with red LED flash.

6. The system will confirm correct PIN-code with red LED flashes and proceed to the programming mode. If the input was incorrect, it will be indicated with long red flash and the system will proceed to previous mode. New input can be attempted after 5 seconds.

## Changing core settings via computer

The system allows programming all settings and updating software of the base unit via the interface micro-USB cable or via radio channel using a computer. It does not matter, whether base unit is installed into a vehicle or not. Software reads the current settings and allows changing them. If base unit has not yet been installed in the vehicle, it should be powered via micro-USB cable while programming. To program using a computer connected via cable, you need a standard micro-USB cable, a computer with Windows and a special piece of software – Pandora AlarmStudio.

### In preparation to the programming following stages should be followed:

- connect micro-USB cable to any free USB socket of the computer;
- start Pandora AlarmStudio (can be downloaded from the web-site);
- enter the programming settings mode by entering the service PIN-code on the base unit using VALET button. Factory preset PIN-code is **1-1-1-1**.

If the software configuration is carried out via the radio interface of 2,4 GHz, special USB programmer RMP-03 should be used.

## Configuring system settings via the wireless interface 2,4 GHz

To change the configuration of the system using a wireless interface 2,4 GHz, enter programming level 10. The system will await a wireless connection from the computer for 2 minutes. If the waiting time limit has expired and the system was not connected to the computer, it will exit this level. If the waiting time limit has expired and the system was not connected to the computer, it will exit this mode.



**WARNING!**  
THIS PROGRAMMING MODE IS AVAILABLE ONLY VIA ALARMSTUDIO.

## Entering the programming menu using VALET button

Level 1	Recording remotes and radio tags into the system's memory
Level 2	Changing the factory preset service PIN-code
Level 3	Reserved
Level 4	Resetting to factory settings
Level 5	Programming RHM-02 engine compartment module
Level 6, 7	Programming radio relays 1 and 2
Level 8	Reserved
Level 9	Changing firmware via the wireless interface 2,4 GHz
Level 10	Configuring system settings via the wireless interface 2,4 GHz
Level 11	Programming validator code of immobilizer (Pin to Drive)
Level 12, 13, 14	Reserved
Level 15	Emergency disabling of immobilizer

## Changing core settings via VALET button

### Level 1 Recording remotes into the system's memory

Enter the first level of programming. Remotes are recorded (paired) one by one. The pause between recording of remotes and radio tags should not exceed 20 seconds.

To pair the radio tag, press button on the tag and hold it for 3 seconds. If the recording was successful, the base unit will emit 1 beep, after that you can move to recording the next tag.



**WARNING!**  
IF THE CONTROL OVER SIREN IS CARRIED OUT USING RHM-02 ENGINE COMPARTMENT MODULE, SIREN SOUND SIGNALS WILL NOT BE EMITTED DURING RADIO TAGS RECORDING!

To finish the recording of the remote units into the system, VALET button should be pressed again, the status LED will produce series of red flashes; then switch on and off the ignition to leave the programming mode.

### Level 2 Changing the factory preset service PIN-code

- Indicator LED is not lit. Press VALET button the number of times equal to the first digit of the new security code. Each pressing of VALET button is followed by red flash of the indicator. The interval between the presses should not exceed 1 second.

- The input will be confirmed with red flash of indicator.
- Enter the other numbers in the same manner.
- The input of the fourth number will be confirmed by series of red LED indicator flashes.
- Enter all four numbers again.
- If you were able to correctly enter code twice, the indicator will produce series of red flashes and a new PIN-code will be recorded, the system will return to the programming mode.
- In case of the incorrect code input the indicator will be lit red and the system will return to a programming mode.

After the input is complete, the indicator fades, the system awaits a new programming level input.



**WARNING!!!**

For proper installation a connected laptop with AlarmStudio software is required. Switch the system to programming mode (see page 12) and select your car model in AlarmStudio for detailed installation instructions. AlarmStudio can be downloaded from [pandorainfo.com](http://pandorainfo.com)

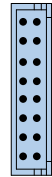
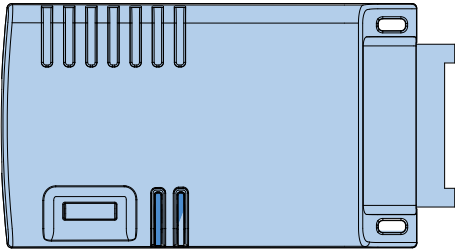

Main socket		
1	White	DATA TX - TO ADDITIONAL DEVICES
2	Red/Black (+)	VALET BUTTON/LED INDICATOR
3	Orange/White	CAN1-HIGH
4	Yellow/White 200mA	CAN2-HIGH / OUT-2 • OPENING CENTRAL LOCK
5	Grey (-) 200mA	OUT-1/INP-1 • DOOR SWITCHES
6	Green (-) 200mA	OUT-4/INP-4 • TO TURN LIGHTS
7	Blue/White (+)	INP-5 • INPUT OF BRAKE PEDAL BUTTON
8	Black (-)	GROUND
9	Blue	DATA RX • TO ADDITIONAL DEVICES
10	Brown/White (-)	INP-3 • FRONT HOOD/TRUNK SWITCHES
11	Orange/Black	CAN1-LOW
12	Yellow/Black 200mA	CAN2-LOW/OUT-5 • CLOSING CENTRAL LOCK
13	Blue/Black (-) 200mA	OUT-3 • ENGINE BLOCK
14	Yellow (+)	INP-2 • IGNITION SWITCH
15	Purple (+) 2A	SIREN
16	Red (+) Fuse 3A	POWER +12V

## MODEL: DXL-O1OOL/O1O1L

### VALET | LED BUTTON | INDICATOR

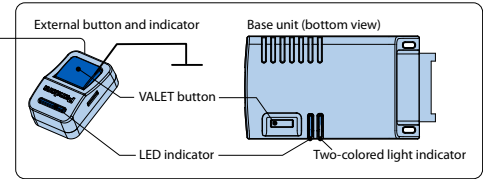

### MAIN SOCKET

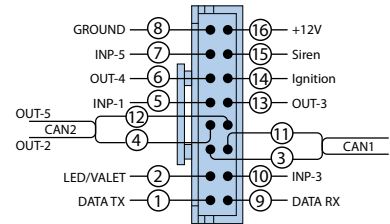

#### Level 4 Resetting to factory settings

To reset to the factory settings, you need to enter programming level 4, then press and hold VALET button for 2 seconds until siren sounds. Once VALET button is released, the status indicator will confirm a successful reset to factory settings with a long red flash.

#### Level 5 Programming of RHM-02 engine compartment module

1. Enter programming mode on level 5.
2. Connect wire 7 (OUT-RHM/programming) of RHM-02 module to wire 2 (ground) and connect to the car grounding spot.
3. When wire 3 is connected (module power supply 12V), the system will confirm the module recording to the system's memory with 1 sound signal of the siren.
4. Disconnect programming wire 7 from wire 2 and insulate it.

#### Level 6, 7 Programming of radio relays 1 and 2

1. Connect the wire 1 of the radio relay to a grounded spot.
2. Select the desired level of the programming menu 6 or 7 for programming radio relays 1 or 2 respectively.
3. Apply power (+12V) on the contacts 3 and 4 of the radio relay. Siren will confirm radio relay recording to the memory with 1 beep.
4. After a successful radio relay recording, contact 3 should be disconnected and insulated, contact 4 should be connected to the constant power supply 12V or to the wire where there is a constant 12V when ignition is switched on (according to the system settings).

#### Level 9 Changing firmware via the wireless interface 2,4 GHz

To change (update) the firmware using the wireless interface 2,4 GHz, enter programming level 9. After entering the system will await a wireless connection from the computer for 2 minutes. If the waiting time limit has expired and the system was not connected to the computer, it will exit this level.

#### Level 10 Configuring system settings via the wireless interface 2,4 GHz

To change the configuration of the system using a wireless interface 2,4 GHz, enter programming level 10, the system will confirm the entering with red flash of LED indicator. The system will await a wireless connection from the computer for 2 minutes. If the waiting time limit has expired and the

system was not connected to the computer, it will exit this level.

#### Level 11 Programming validator code of immobilizer (Pin to Drive)

##### 1. Select the button to set the secret validator code of immobilizer.

To do this, enter level 11 of programming and press the selected button (e.g. wheel 'volume up' button), LED indicator will confirm input with orange flashes. If there are no orange flashes when any button is pressed, then this button is not recognized by the system, select a different button. After the button was chosen, press VALET button. Security system will memorize the last pressed button (which was pressed before VALET button) as a button to enter PIN-code of immobilizer and will await input of the first digit of PIN-code.

##### 2. Program the immobilizer deactivation PIN-code.

Enter the first digit by pressing the previously selected button (pause between pressing must be no more than 1 second). The base unit will confirm entering with red flash of LED indicator.

Input the second (third, fourth) digit by pressing the previously selected button. The base unit will confirm entering with red flash of LED indicator.

Input the required number of digits (up to 4) and then press VALET button. The system will confirm receiving of the secret validator code with long red flash of LED indicator and will expect for confirmation of PIN-code.

##### 3. Confirm the immobilizer deactivation PIN-code.

Input PIN-code again similarly to the programming procedure and press VALET button. The system will confirm correct PIN-code with red and green flashes of LED indicator and will memorize PIN-code, then will proceed to the programming mode awaiting level input. Incorrect confirmation is indicated with long red flash of LED indicator, after that the system will return to a programming mode.

#### Level 15 Emergency disabling of immobilizer

To deactivate the immobilizer/Antihijack function, enter the programming level 15, the system will confirm the entering with green flash of LED indicator. Input the first digit of the secret code using VALET button (press the button a number of times, equal to the first digit; pauses between presses should not exceed 1 second). The system will confirm input with red flash of LED indicator. Enter the other three digits in the same manner. The correct input will be confirmed with 2 short sound signals of the siren and with red flash of LED indicator. To activate immobilizer/Antihijack function, enter level 15, LED will confirm input with red flash. Press VALET button once, siren will emit 1 short beep.

## ADDITIONAL DEVICES

### Blocking radio relay

For Pandora DXL-0100L/0101L optionally blocking RR-100 radio relay is available. Blocking radio relay with built-in accelerometer should be placed in the engine compartment. Herewith zone of built-in aerial 2,4 GHz should not be shielded.

Provide a rigid fastening to the car body or to the fixed wirings. It is forbidden to hide the module in wiring. Radio relay power connects either from the ignition or from a constant power wire. Radio relay is normally closed, blocking is carried out only on unauthorized movement.



**WARNING!**  
DO NOT PLACE RADIO RELAYS DIRECTLY ON ENGINE!

### RR-100 Radio relay connection

**Wire 1** (Black) should be connected to the car body in a grounding spot or to a reliable conductor, connected to car body or to any grounded device. The wire should be connected **FIRST** during installation.

**Wire 3** (Black) is used to program radio relay.

**Wire 4** (Black) should be connected to reliable conductor with constant voltage of 12V or to any wire, which has constant voltage of 12V (it depends on the system settings) when engine is running and this voltage does not disappear when driving.

**Wire 2** (Black) and **5** (Black) connects to the circuit being blocked. Switching current should be no more than 10A long-term and 20A for up to 1 minute (if switching circuits are without inductive component in the load). Contacts of blocking relay are connected to blocking wires as normally closed (N.C.).

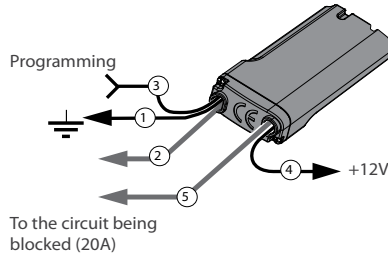

### Programming of radio relay

Radio relay can be programmed on level 6 and 7. Level 5 is used to program engine compartment module RHM-02.

1. Connect wire 1 of radio relay to the grounding spot.
2. Select desired level of the programming menu 6, 7 to program radio relay 1, 2 respectively.
3. Apply power (12V) to the contacts 3 and 4 of radio relay. The siren will confirm recording of radio relay to the system's memory with 1 beep.

After successful recording of radio relay switch off and insulate contact 3, connect contact 4 to the constant power 12V or to any wire, which has constant voltage of 12V when engine is running.

### Radio module of engine compartment RHM-02

This module is designed to simplify the system installation and wiring in the engine compartment, it allows to control additional devices (siren, tachometer, engine blocking, motion sensor and etc.) via 2,4 GHz radio channel.

Engine compartment module RHM-02 is installed discreetly in the engine compartment on the vehicles with 12V on-board voltage.



**WARNING!**  
DO NOT INSTALL THE MODULE NEAR THE EXHAUST MANIFOLD, AS WELL AS IN PLACES WITH HIGH HUMIDITY!

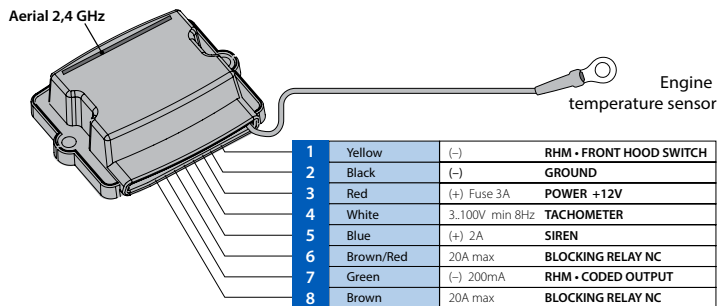

**WARNING!!!**

Place radio module unit wires down! When installing the device, avoid shielding of built-in 2,4 GHz aerial by metal parts of the car body (no less than 3 cm from metal surfaces).

**Wire 1** (Yellow) is input of front hood limit switch. RHM input (front hood trigger) can operate in accordance with selected logic in the 'input table' of the system (control of glow plugs, generator charge lamp and etc.).

**Wire 2** (Black) is ground, this wire should be connected to the car body in a grounding spot or to a reliable conductor, connecting car body or to any grounded device. The wire should be connected FIRST during installation.

**Wire 3** (Red) is power supply 12V, this wire connects to any wire that has constant voltage of 12V. The circuit should be protected by a fuse (3A). If this condition is not satisfied, device can be damaged and it can impact the security features of the system.

**Wire 4** (White) is analog tachometer input, this wire should be connected to wire of tachometer or signal wire of injector, a wire with stable impulses of any polarity that correspond with motor shaft rotation frequency.

**Wire 5** (Blue) is a siren, this wire connects to siren control wire (+) (maximum load current is 2A).

**Wire 6** (Brown/Red) and **8** (Brown) are normally closed relay outputs, maximum load current is 20A, can be used as engine blocking relays. Engine blocking is carried out taking built-in accelerometer data into account.

**Wire 7** (Green) is coded output (channel), maximum load current is 200mA, used to control additional devices (e.g. HM-05). The output works via programmed logic of 'Block of timer channels 10(K)' section in AlarmStudio. In case additional front hood module HM-05 is being programmed, 'Block of timer channels 10(K)' should be switched on/off. When front hood lock is controlled, engine compartment module RHM-02 take into account the status of the hood trigger via its own input or via any input of the system.

### Programming mode (recording) of RHM-02 module

1. Enter the programming mode on the level 5.
2. Wire 7 (OUT-RHM/programming) of RHM-02 module connects to wire 2 (ground) and connects with a grounded spot of the car.
3. After wire 3 is connected (module power 12V), the system will confirm recording of the module to the system's memory with 1 beep of the siren.
4. Disconnect the programming wire 7 from wire 2 and insulate the wires.

## IMPORTANT INFORMATION

### Any problem can be solved

Problem	Solution
Warning/alarm level of the shock, motion and tilt sensor triggers constantly.	Too high sensitivity. Reduce sensor sensitivity.
When arming, siren emits 4 short sound signals instead of 1.	One of alarm zones is not armed (doors are opened, front hood or trunk is unlocked) or turn lights are enabled.
The system cannot be disarmed using RF tag button.	RF tag battery is discharged. Replace it.

## Siren sounds and turn light signals

Signal name	Signal description
Alarm mode, PANIC mode	Incessant sound and light signals for 30 seconds
Arming	1 sound and 1 light signals
Disarming	2 sound and 2 light signals
'Sensors triggered' signal when disarming	4 sound and 4 light signals
'Sensor malfunction' signal when arming	4 sound and 4 light signals
Sensor warning level triggered	3 sound and 1 light signals

## Meaning of the indicator LED colors

Indicator status	Meaning
Short red flashes	The system is armed
Lit red	The system is preparing for automatic arming
Red and green flashes	PIN-code confirmed, immobilizer disabled
Faded	The system is disarmed

## Glossary of terms

**AlarmStudio** – an installation helper software that is to be installed on a Windows PC (preferably, laptop). AlarmStudio allows changing any parameters in the system and provides installation tips for particular cars. Easy to use and intuitive, AlarmStudio is required for in-depth and highly customized installation. Installation without AlarmStudio, although entirely possible, may be incomplete and lacking in functionality.

**Base Unit** – it is a small box that acts as a 'brain' of the system. It contains a printed circuit board, sensors and supplementary devices like 3D accelerometer and sockets for connecting it to car systems. Powerful processor unit and ingenious algorithms allow for hundreds of programmable parameters, accessible via AlarmStudio (and via VALET button for some).

**Car alarm system** – a set of third-party electronic devices that are installed in a car body and connected to its electric and data networks in order to provide enhanced security.

**Car service-security system** – same as car alarm system but with more service options, e.g. telemetry, remote engine start, various control options.

**Channel** – a name we use in our service-security systems to indicate a combined position and function of particular output socket and corresponding wiring.

**Original security system** – a built-in security system that is present on some car models. You can set up particular logic of interaction between this system and ours – control over it or a slave mode.

**Telemetry** – in car service-security systems is a combined capability to gather, process and convey to user various data regarding the car – temperatures, voltages, fuel level, sensor data, etc.

**Timer channel** – a term we use in our service-security systems to name channels that activate additional options or accessories (e.g. seat heating, light path, additional block relays). Any channel (output) can be set as timer channel, that can be activated from the remote, or incorporated into scheduled and sequential routines. To assign timer channels, use AlarmStudio.

## System modules layout

Ask the installer to mark system's modules on the picture provided. This information can be important for diagnostics in case system malfunctions.

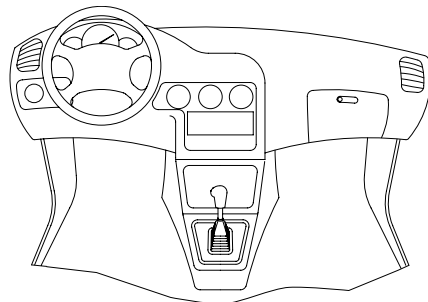

- 1 Base unit
- 2 VALET button
- 3 Blocking radio relay
- 4 Additional sensor
- 5 GSM aerial
- 6 Automatic start module
- 7 GPS receiver

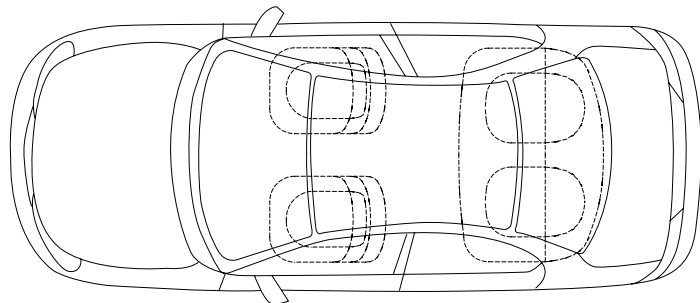

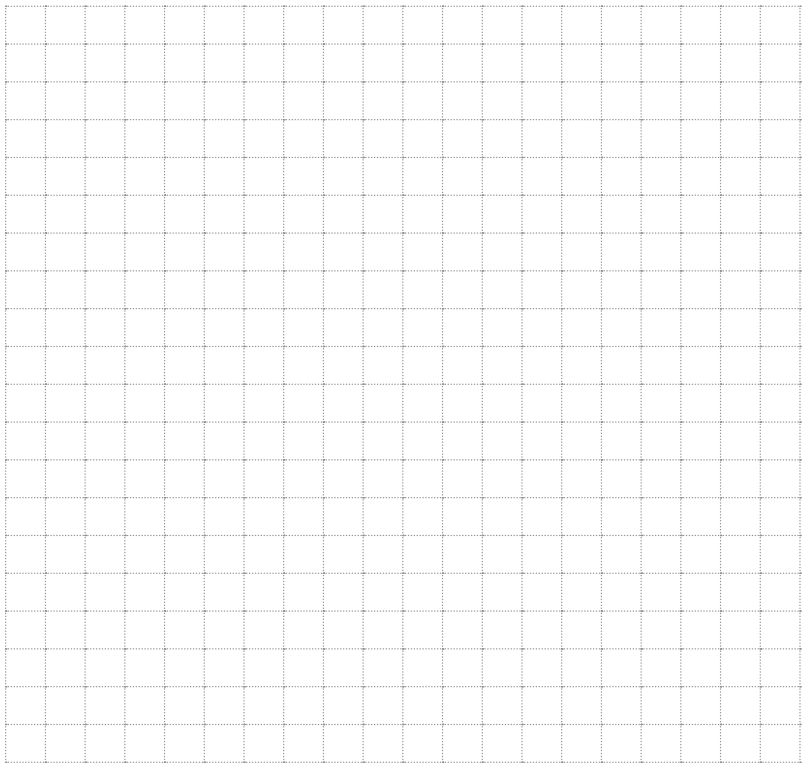

## Warranty obligations

Manufacturer guarantees correct operation of the service-security system if exploitation, installation, storage and transportation conditions described in this manual were met.

The system should only be used according to installation scheme and user manuals.

The system is meant to be installed by the professional car electronics installers. We recognize that outside Russia the system can be installed by amateurs – those installations are still a subject of limited warranty. The installer should fill in installation certificate that is included in this manual.

Parts malfunctioning during warranty period on the fault of the manufacturer should be repaired or replaced by the installation center of the manufacturer or by certified service center. List of certified service centers outside Russia can be found on pandorainfo.com

The user loses the right for warranty services in the following cases:

- when warranty period expires;
- if exploitation, installation, storage or transportation conditions were not met;
- if there is mechanical damage of the external parts of the system after it is sold. This includes: fire damage, consequential damage in case of car accident, aggressive liquids and water seeping damage, damage caused by improper use;
  - if the damage was caused with incorrect settings and parameter adjustment;
  - if system devices are replaced with any devices that are not recommended by the manufacturer;
  - if manufacturer sealing is broken;
  - if there is no properly filled warranty card and installation certificate.

Warranty period is 3 years since the moment of purchase, but no more than 3,5 (three and a half) years since the moment of production.

This warranty does not include batteries of the remotes, as they have their own service life time.

Maintenances and repairs of the system with expired warranty period are carried out at the expense of the user on a separate contracts between the user and the installer/service center.

## Transportation rules

Products should be transported in the original packaging by any means of transport as long as they are protected from mechanical damage and precipitation.

Packaged products should be stored on racks in piles of 6 or less boxes, in enclosed, dry, heated rooms (no less than 1m from heating) which exclude possible interaction with moisture, oil products and damaging environmental factors.

## Installation certificate

I, the undersigned \_\_\_\_\_  
Position, name

professional installer, certify that installation of the service-security system, specified below, was carried out by me in accordance with manuals and schemes provided by the manufacturer.

### Car specifications:

Car model \_\_\_\_\_

Type \_\_\_\_\_

ID number (VIN) \_\_\_\_\_

Registration number \_\_\_\_\_

### Security system specifications:

Model Pandora DXL-0100L/0101L

Serial number \_\_\_\_\_

Service center name, full address and installer's stamp \_\_\_\_\_  
\_\_\_\_\_  
\_\_\_\_\_

Signature \_\_\_\_\_/\_\_\_\_\_

Signator

Work accepted \_\_\_\_\_/\_\_\_\_\_

Signator

Date « \_\_\_\_ » \_\_\_\_\_ 20\_\_ y



## Acceptance certificate

Pandora DXL-0100L/0101L is in conformity with Electromagnetic Compatibility Directive EMC 2004/108/EC and R&TTE Directive 1999/5/EC

Serial number \_\_\_\_\_

Date of production \_\_\_\_\_

Responsible person's signature

(stamp)

Packager \_\_\_\_\_

Signature (personal stamp)

---

## Warranty card

Model Pandora DXL-0100L/0101L

Serial number \_\_\_\_\_

Date of purchase « \_\_\_\_ » \_\_\_\_\_ 20 \_\_\_\_ y

\_\_\_\_\_  
Seller's (installer's) stamp

\_\_\_\_\_  
Seller's signature \_\_\_\_\_